

Sentinel® Connector Systems Inc.

1953 Stanton Street

York, Pa. 17404

PART NO.: 111-08080028L34

- * EIGHT CONDUCTOR MODULAR PLUG
- * FOR HIGH SPEED APPLICATION
- * FOR CONDUCTORS WITH AN O.D. RANGE OF .037/.042
- * USES .012 CONTACT
- * PRODUCT REQUIRES CONDUCTIVE LOAD BAR

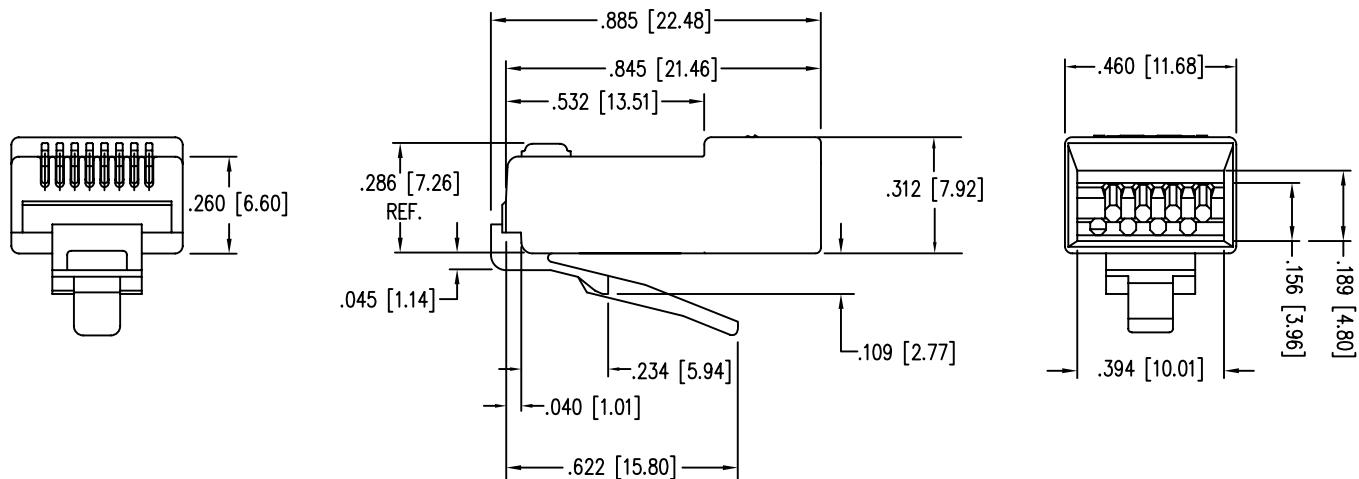
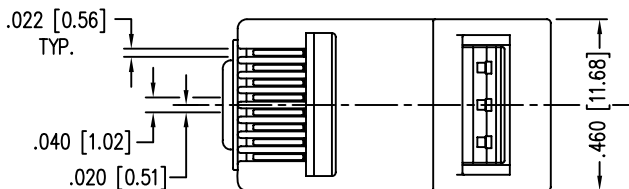
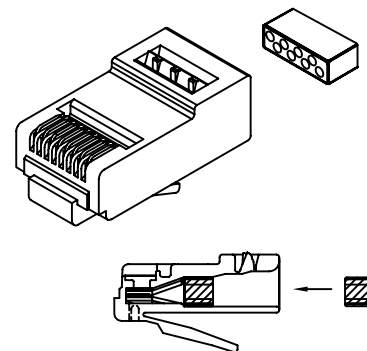

"PATENTED"

SPECIFICATIONS :

PERFORMANCE:

MEETS OR EXCEEDS CATEGORY 6 ANSI/EIA 568-C.2
PERFORMANCE TUNED TO CABLES MEETING CATEGORY 6 SPECIFICATIONS.

CONTACT MATERIAL:

PHOSPHOR BRONZE - .012 THK

CONTACT PLATING:

50 MICRO-INCH : OTHER PLATING OPTIONS AVAILABLE
SELECTIVE 24 CARAT HARD GOLD PLATE IN CONTACT AREA
OVER 100 MICRO-INCH MINIMUM NICKEL PLATE
PER CURRENT SELECTIVE GOLD PLATING REQUIREMENTS.

PLUG MATERIAL:

POLYCARBONATE

PLUG TOLERANCES

COMPLIES WITH F.C.C REQUIREMENTS

AND DIMENSIONS:

File# E188111

U.L. RECOGNIZED

94-V0

FLAME AUTO EXTINGUISH

OPERATION TEMPERATURE:

-40°C TO +85°C

INSERTION/EXTRACTION LIFE:

1000 CYCLES

CONTACT RESISTANCE:

10 MILLOHMS MAX.

CURRENT/VOLTAGE:

30 VAC/42 VDC AT 1.5 AMPS

(RoHS COMPLIANT)

